

# Safenet Certification Services Ltd.

Ducart Suite, Castletroy Park Commercial Campus, Limerick, V94 Y6FD, Ireland

Tel: +353 61 50 2046

e-mail: office@safenetcs.ie

Website: www.safenetcs.ie

European Notified Body 2805

## EC Type Examination Certificate

This is to certify that

### Sanil Electric Co., Ltd.

481 Sihwabencheo-ro, Danwon-gu, Ansan-si, Gyeonggi-do, Korea

Has had a range of Safety Light Curtains examined with regards to the Directive 2006/42/EC as amended.

In respect of the **SLC-6409**

Manufactured by:

### Sanil Electric Co., Ltd.

481 Sihwabencheo-ro, Danwon-gu, Ansan-si, Gyeonggi-do, Korea

1. The technical file contains all the relevant information.
2. Having verified that the appropriate tests have been conducted.
  - 2.1. The standards and transposed standards, including EN IEC 61496-1:2020 and EN IEC 61496-2:2020, have been applied correctly.
  - 2.2. The example representing series production of the item, complies with the essential health and safety requirements of the Directive 2006/42/EC as amended.
  - 2.3. The technical file contains all the information required to include the models listed in the attached annex to this certificate.
  - 2.4. The technical file also contains evidence that the product meets the requirements of Type 4 according to EN IEC 61496-1:2020 and EN IEC 61496-2:2020 and that it is suitable for applications regarding EN 62061:2005+A2:2015 SIL 3 and EN ISO 13849-1:2015 PL e.

Certificate Number: 5242200922

Date: 31/10/2022      Expiry Date: 31/10/2027

Signed for Safenet Certification Services Ltd.



Peter McNicol  
Technical Manager

This Document remains the property of Safenet Certification Services Ltd and will be returned to them if so requested. The client is required to request a review to ensure continued compliance of the machinery on a 5 yearly basis to check for changes in the state of the art and validity of the certificate.



Machinery  
Directive  
Number  
2805

# Safenet Certification Services Ltd.

Ducart Suite, Castletroy Park Commercial Campus, Limerick, V94 Y6FD, Ireland

Tel: +353 61 50 2046

e-mail: office@safenetcs.ie

Website: www.safenetcs.ie

European Notified Body 2805

## EC Type Examination Certificate

### Annex Certificate 5242200922

Models included:

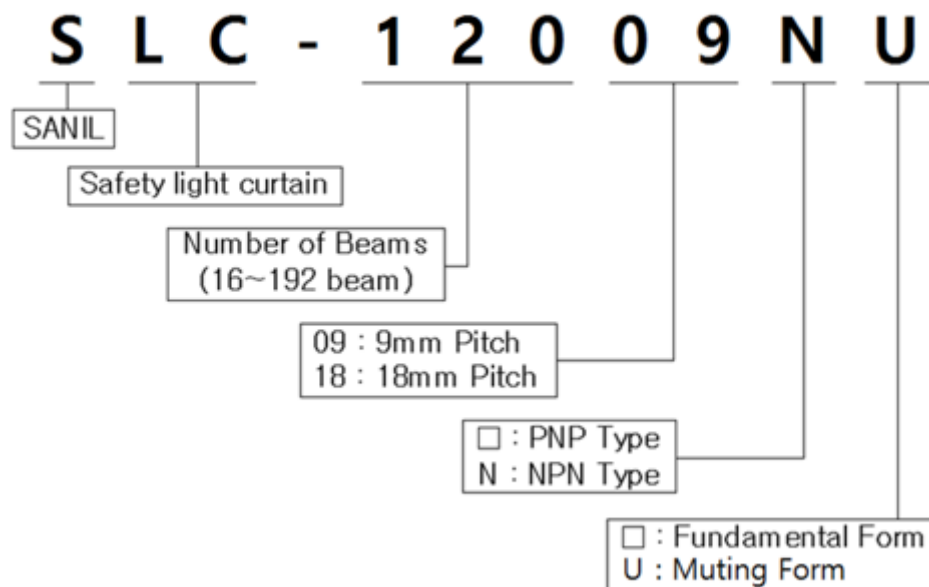

Machinery  
Directive

Number  
2805

This Document remains the property of Safenet Certification Services Ltd and will be returned to them if so requested. The client is required to request a review to ensure continued compliance of the machinery on a 5 yearly basis to check for changes in the state of the art and validity of the certificate.